

SGB型 机舱组合报警系统 Cabin combination alarm system

► 概述

Overview

SGB型机舱组合报警系统是机舱及其它场所重要信息的集中，在发生船舶、机器及人员安全等情况时发出声光报警信号，能在嘈杂环境下迅速告知船员，是船舶安全运行必不可少的重要系统。

系统符合国际电工委员会IEC60092-203标准；满足国内外船级社规范、IMO A.1021规范。

SGB cabin combination alarm system is the centralized system for a variety of alarm information in the engine room and other places. It is used to issue sound and light alarm signals under the situations of ship safety, machine safety and personnel security, and it is able to promptly inform the operators in a noisy environment. It is an essential and critical system for the safe operation of the ship.

The system complies with IEC60092-203 standard of International Electrotechnical Commission, meet the specification of domestic and foreign classification society and the IMO A.1021 specification.

► 产品特点

Product features

■ 系统可根据不同的报警信息发出相应的满足规范的报警音调和灯光信号

The system according to different alarm information can issue relevant alarm pitches and light signals that meet the specifications

■ 组合声光组合报警灯柱采用高亮度LED信号灯和报警电笛，具有功耗小、亮度高、声响大的特点

Sound and light combined alarm light column is fitted with high brightness LED lights and alarm electric siren, with the characteristics of low power consumption, high brightness, and loud sound

■ 选用公司标准AE箱体，外形美观

Adopting the company's standard AE type box, with nice appearance

■ 系统采用双电源供电，保证了工作的可靠性

The system is provided with dual power supply, ensuring the reliability of the work

■ 系统内部信号传输方式可选择开关量和通讯两种方式

Two ways of switching value and communication method can be selected for the internal signal transmission of the system

■ 电笛根据信号的优先级，发出相应的音调

The electric siren can issue relevant pitches according to the priority of the signal

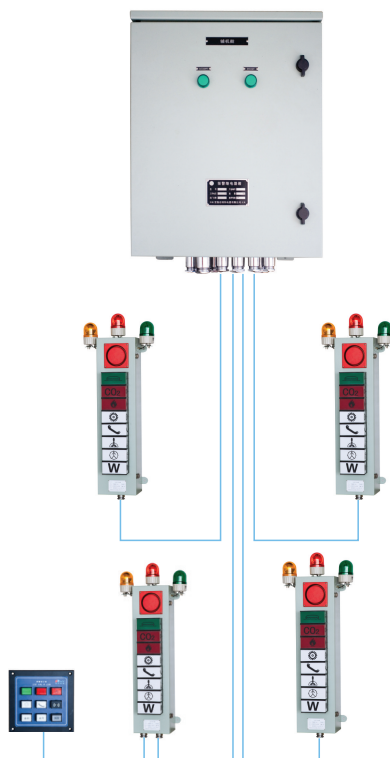

▶ 产品组成

Product composition

■ 机舱组合报警控制箱

Cabin combination alarm control box

■ 机舱组合报警灯柱

Cabin combination light column

■ 机舱报警复示板

Cabin alarm repeater panel

▶ 技术指标

Technical index

■ 工作电压:

主电源: 单相AC220V ± 10% 50/60Hz

辅助电源: 单相 AC220V ± 10% 50/60Hz 或者
DC24V ± 20%

Main power: single-phase AC220V ± 10% 50/60Hz

Standby power: single-phase AC220V ± 10% 50/60Hz 或者
DC24V (± 20%)

■ 报警声强: ≈ 115dB(距离1米处) (组合报警灯柱)

≈ 90dB(距离1米处) (组合报警复示板)

Alarm sound intensity:

≈ 115dB (1 meter distance) (combination alarm light
column)

≈ 90dB (1 meter distance) (combination alarm repeater
panel)

■ 功耗: 组合报警灯柱: 100W/块

组合报警复示板: 10W

Power:

Combination alarm light column: 100W / block

Combination alarm repeater panel: 10W

■ 安装方式: 组合报警控制箱: 壁挂式

组合报警灯柱: 壁挂式

组合报警复示板: 嵌入式

Installation:

Combination alarm control box: wall mounted

Combination alarm light column: wall mounted

Combination alarm repeater panel: embedded

■ 防护等级: 组合报警控制箱: IP44

组合报警灯柱: IP44

组合报警复示板: IP20

Protection grade:

Combination alarm control box: IP44

Combination alarm light column: IP44

Combination alarm repeater panel: IP20

■ 报警类别

Selection of alarm category

名称 Name	符号标志 Sign indicator	信号灯颜色 Color of signal light	旋转灯颜色 Color of rotating light	民品常用音调	推荐优先级
通用报警 General alarm		绿色 green	绿色 green	7短1长	2
CO2施放报警 CO2 release alarm	C02	红色 red	红色 red	单音连续	1
火灾报警 Fire alarm		红色 red	红色 red	连续调频	3
机器处火警 Machine fire		红色 red	红色 red	连续调频	3
水雾报警 Water mist alarm		红色 red	红色 red	单音连续	4
机器故障报警 Machine fault alarm		黄色 yellow	黄色 yellow	双音调	4
轮机员报警 Engineer alarm		黄色 yellow	黄色 yellow	快速调频	4
车钟报警 Telegraph alarm		白色 white	黄色 yellow	单音断鸣	5
电话呼叫 Phone call		白色 white	黄色 yellow	单音断鸣	5
自定义 User-defined	自定义 User-defined	自定义 User-defined	自定义 User-defined	自定义 User-defined	自定义 User-defined

■ 报警声音

Selection of alarm sound

声音名称 Sound name	波形 Waveform
七短一长 Seven short and one long	
单音连续 Continuous individual tone	
单音断鸣 Interrupted individual tone	
紧急调频 Urgent frequency modulation	
双音调 Dual ton	
连续调频 Continuous frequency modulation	

■ 产品标准尺寸见下表:

Standard sizes that can be selected are shown in the following table

设备名称 Equipment name	报警点数 Number of alarm points	外形尺寸mm Outline dimensions(mm)			安装尺寸 Installation dimensions (mm)		备注 Remarks
		宽 (A) W	高 (B) H	深 (C) D	宽 (D) W	高 (E) H	
组合报警灯柱 Combination alarm light column	4	220	580	120	250	400	Fig.1
	5	220	650	120	250	470	
	6	220	720	120	250	540	
	7	220	790	120	250	610	
	8	220	860	120	250	680	
组合报警复示板 (嵌入式) Combination alarm repeater panel (embedded)	8	192	192	65	167	167	Fig. 2
组合报警控制箱 (壁挂式) Combination alarm control box (wall mounted)	8	500	700	210	380	740	Fig. 3

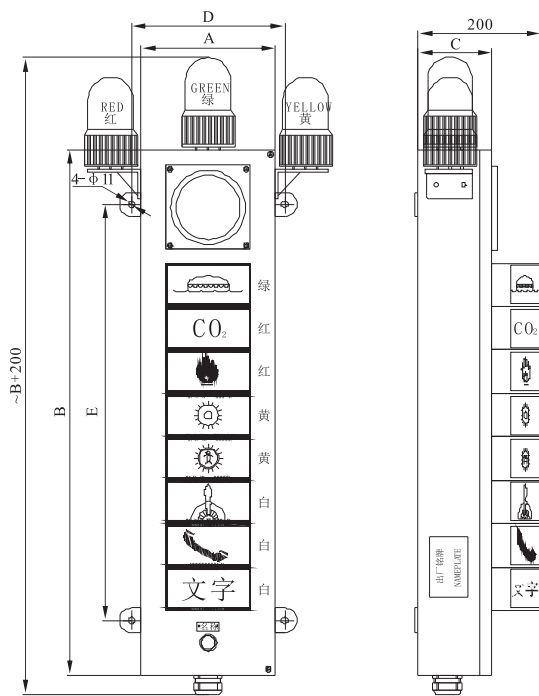

Fig.1

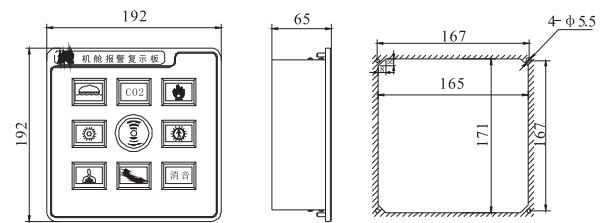

Fig.2

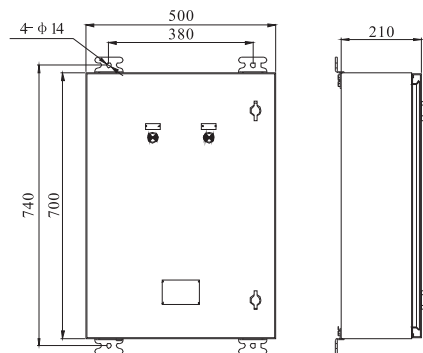

Fig.3

型号命名

Model naming

机舱组合报警系统 Cabin combination alarm system	SGB	-J	<input type="checkbox"/>	<input type="checkbox"/>	<input type="checkbox"/>	/	<input type="checkbox"/>
组合报警控制箱 Combination alarm control box							
报警点数 Number of alarm points							
报警灯柱数 Number of alarm light columns							
复示板数量 Number of repeater panels							
传输方式 T:通讯 C:开关量 Transport mode T: communication C: switching value							

机舱组合报警系统 Cabin combination alarm system	SGB	-D	<input type="checkbox"/>	/	<input type="checkbox"/>
报警灯柱 Alarm light column					
报警点数 Number of alarm points					
传输方式 T:通讯 C:开关量 Transport mode T: communication C: switching value					

机舱组合报警系统 Cabin combination alarm system	SGB	-F	<input type="checkbox"/>	<input type="checkbox"/>
报警复示板 Alarm repeater panel				
报警点数 Number of alarm points				
安装方式 Q:嵌入式, B:壁挂式 Installation mode: Q: embedded, B: wall-mounted				

选型说明

Selection description

例: SGB-J621/C

表示机舱组合报警控制箱有6路报警, 2个报警灯柱, 1块报警复示板, 通过开关量硬线传送信号。

The combination alarm control box includes 6 alarm points, 2 alarm light columns and 1 alarm repeater panel, and it transports the signal through the switching value.